

Detonation Sensing Interface System

Model DSI - G3500 Series Caterpillar Engine

The Murphy Detonation Sensing Interface System utilizes a pair of highly sensitive accelerometers to detect detonation. In the event of detonation, the DSI signals the Murphy IntelliSpark® System, via 4/20 mA control signal, which responds by immediately retarding the timing thus eliminating the potentially harmful effects of continuous detonation.

Features

- Utilizes advanced piezoelectric accelerometer sensors to provide real-time analog signal
- Signal is proportional in amplitude to the levels of vibration detected
- Sensors respond over wide range of frequencies up to 10 K Hz
- Retards timing to reduce vibration intensity or eliminate it entirely
- Sensor range - 0 - 500 g's
- Detect any source of vibration

Benefits

- Easy-to-use controller interface
- Detects detonation tendencies at low levels before they reach greater intensity and cause engine damage
- Flexible controls and useful information for operators
- Wide bandwidth allows detection of most mechanical vibration sources including detonation
- Complete installation kits, wiring guidelines and sensor kits provided



Dimensions

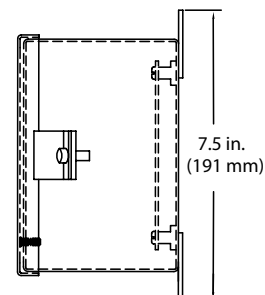
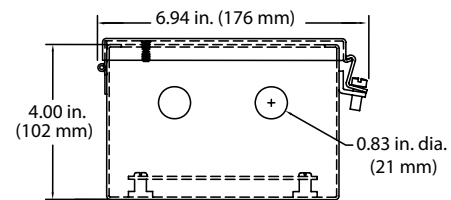
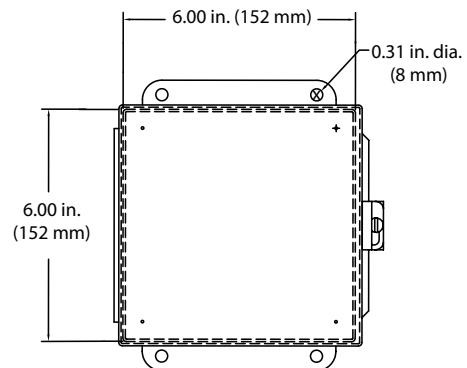

Specifications

Power Requirements: 18-30 VDC 300 mA max
Controller Operating Temp: -40° F to 158° F (-40° C to 70° C)
Sensor Operating Temp: -40° F to 248° F (-40° C to 120° C)
Sensor Frequency: 20 - 500 Hz
Sensor Sensitivity: 10 mV/g 500 g F. S.

Control Inputs

The 1/REV signal must be provided. Two interfaces are available for customer convenience.

Option 1. IS_ISO_1/REV-IS_ISO_RTN: This input connects back to the IntelliSpark Isolated_ 1/REV output pair.

Option 2. 1/REV_In: This interface is designed to be used directly by a mag pick sensor. It can be wired in parallel to the IS 1/REV mag pick up. It can also be connected in parallel to a Hall-effect sensor if in use.

Control Output: Vanalog_Out: This is a 1-5 volt open-circuit output level that when terminated externally by 250 ohm becomes a 4-20 mA current signal. Note: The Murphy IntelliSpark ignition system already has an internal 250 ohm resistor across this input.

Shut-down Output: This is an Open-Drain type interface
Maximum current when activated: 1.0 amps
Maximum externally applied voltage when de-activated: 100 V

Panel Controls and Indicators

Power On Switch: Applies 24 VDC to the electronics and sensors.
The knock sensor cable should never be removed or installed with power on.
Power On Indicator provides verification that power is applied.

Sensor 1(2) Low Level Lights: These indicators will come on when the engine is running over 400 RPM and the sensor output is below minimum level. It's an indication that the sensor is not sensing vibration levels during normal running operations. This may be due to the sensor becoming loose or the cable is removed or the engine is running at idle or unloaded when very low levels of vibration are generated.

Shutdown: This indicator will come on if the system detects three heavy detonation events present for three successive revolutions. The Shutdown output will activate, and it can be tied into a panel or directly to a Murphy IntelliSpark Ignition system to kill ignition.

Shutdown Reset: After a shutdown occurs, this push button clears the shut-down indicator and deactivates the shut-down output for subsequent startup.

Internal Indicators: Flashing amber LED indicates firmware is operating normally.

Applications: Any Caterpillar 3500 series engine.

How to Order

Please contact your local Murphy Sales Representative for a complete System and Murphy products from Enovation Controls. A local distributor can be found at www.fwmurphy.com/wheretobuy.

Part Number	Description	Notes
72700173	Detonation Sensing Kit, Includes 1 Accelerometer, 1 Cable, and 1 DSI	
72700154	Detonation Sensing Kit, Includes 2 Accelerometer, 2 Cables, and 1 DSI	
72700149	Detonation Sensing Interface (DSI)	
72700203	Accelerometer 3059M6, Use with DSI	
00031023	Cable, Unshielded, Accelerometer, 50' Wire, 2-Pin	
72700265	Cable, Shielded, Accelerometer, 4' Stainless, 50' Wire, 2-Pin	